

DESIGNED AND BUILT IN THE U.S.A.
HAWG WIRED

CS300/RS400 AMPLIFIER SYSTEMS

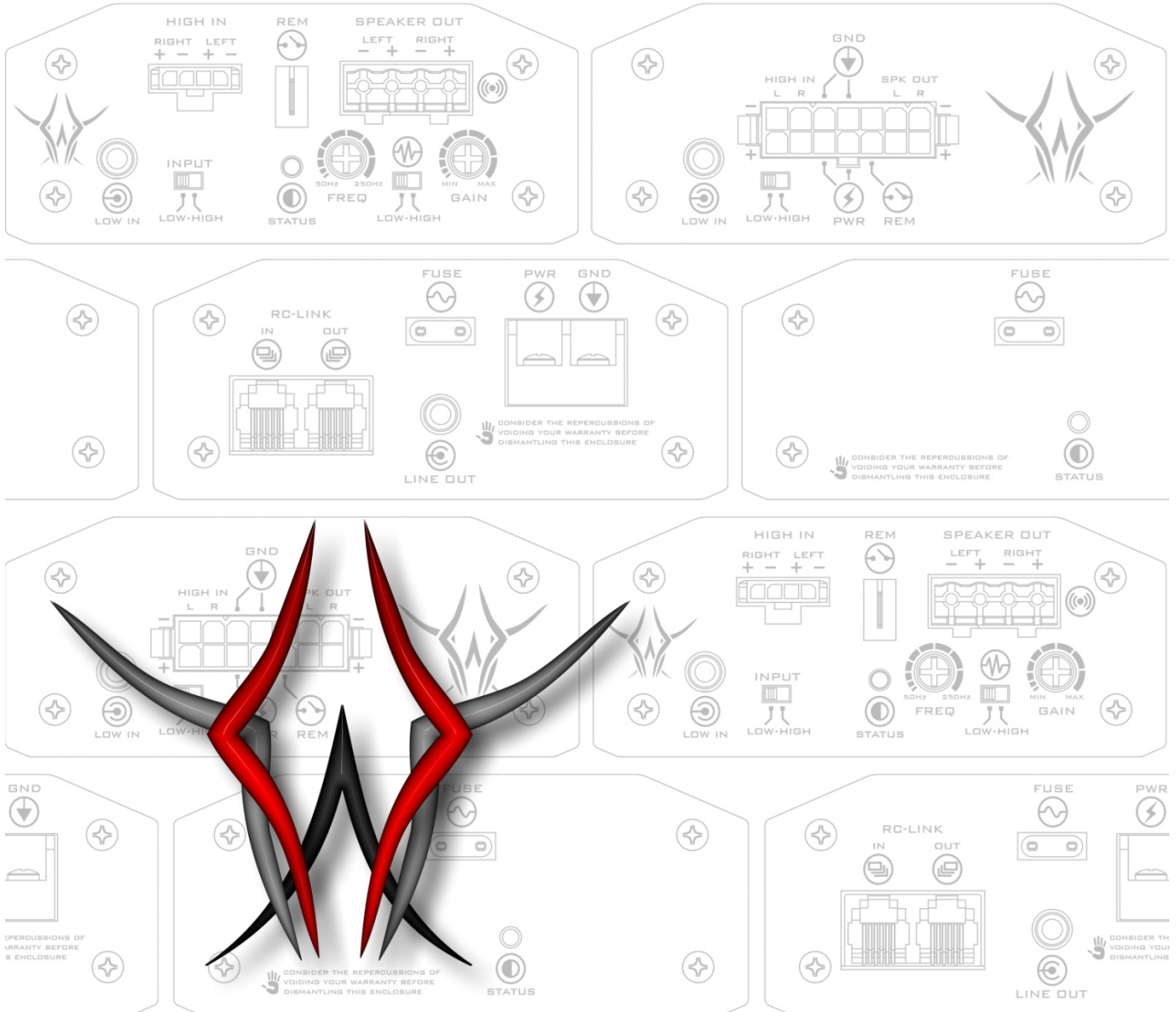

INSTALLATION GUIDE

INTRODUCTION

CONGRATULATIONS! YOU'VE JUST PURCHASED WHAT WE CONSIDER TO BE THE FINEST MOTORCYCLE AUDIO EQUIPMENT AVAILABLE. WE TAKE PRIDE IN THE FACT THAT YOU'VE CHOSEN HAWG WIRED PRODUCTS, AND WELCOME YOU TO OUR FAMILY OF AUDIOPHILE ENTHUSIASTS. OUR GOAL HERE IS SIMPLE - TO BRING HIGH PERFORMANCE AUDIO FIDELITY TO YOU, THE RIDER, WITHOUT COMPROMISING YOUR BIKE'S ELECTRICAL SYSTEM OR STORAGE SPACE. SOME SIDE EFFECTS MAY OCCUR HOWEVER, INCLUDING BUT NOT LIMITED TO; PUZZLED LOOKS FROM OTHER MOTORISTS, OCCASIONAL SHOUTS FROM YOUR NEIGHBORS, AND THE ENVY OF YOUR FRIENDS. AFTER YEARS OF DESIGN AND ENGINEERING, CUSTOM CRAFTSMANSHIP, AND A GRAVE FOR CLEAN, CLEAR, LOUD MUSIC, WE BELIEVE WE'VE NAILED THIS STUFF DOWN RIGHT.



THANK YOU FOR YOUR SUPPORT
THE HAWG WIRED TEAM

SERIAL NUMBER

PLEASE RECORD THE MODEL AND SERIAL NUMBER(S) OF YOUR EQUIPMENT IN THE SPACE PROVIDED BELOW AS YOUR PERMANENT RECORD. THESE NUMBERS CAN BE FOUND ON THE FRONT AND/OR BOTTOM OF EACH COMPONENT. THIS WILL ASSIST US WITH YOUR FACTORY WARRANTY COVERAGE, AND MAY BE USEFUL TO YOU IN THE UNFORTUNATE EVENT THAT IT'S STOLEN.

MODEL NUMBER(S):	SERIAL NUMBER(S):
_____	_____
_____	_____
_____	_____
_____	_____

KIT CONTENTS

KIT ITEMS INCLUDED (BY QUANTITY):	WX400	CS300	RS400
2 CHANNEL 300/400 POWER AMPLIFIER		1	1
6' 10 AWG POWER WIRE W/BLACK SLEEVE	1		
24" 10 AWG GROUND WIRE	1		
36" REMOTE TURN-ON WIRE	1		
24" HIGH LEVEL INPUT CABLE		1	1
LOW LEVEL INPUT CABLE (L/R RCA TO 3.5MM)	1		
LOW LEVEL LINK CABLE (3.5MM TO 3.5MM)	1		
SPEAKER OUTPUT TERMINAL PLUG		1	1
LARGE VELCRO PAD		1	1
30 AMP ATC FUSE	1		
8" BLACK ZIP TIE	6		
DIELECTRIC GREASE PACKET	1		
ALCOHOL CLEANING PAD		2	2

BEFORE YOU BEGIN













THIS SECTION IS INTENDED TO BRING YOU UP TO SPEED WITH OUR DOCUMENTATION CONVENTIONS. WE RECOMMEND READING THIS MANUAL THOROUGHLY BEFORE BEGINNING YOUR INSTALLATION TO ACHIEVE A TROUBLE FREE, LONG LASTING OUTCOME.

TERMINOLOGY USED IN THIS MANUAL:

SOURCE UNIT	REFERS TO THE DEVICE THAT SUPPLIES THE AMPLIFIER WITH AUDIO INPUT, TYPICALLY YOUR RADIO, HEAD UNIT, MEDIA DEVICE, ETC.
POWER AMPLIFIER	CS300, RS400, MASTER 2 CHANNEL AMPLIFIER THAT FUNCTIONS STANDALONE OR LINKED IN SERIES. THE RED OR BLACK BOX IN THIS KIT.
REMOTE TURN-ON WIRE	USED TO SWITCH THE AMPLIFIER SYSTEM ON/OFF, USUALLY CONTROLLED BY YOUR IGNITION SYSTEM (CIGARETTE LIGHTER METHOD), OR BY THE REMOTE LEAD OF AN AFTERMARKET SOURCE UNIT.
LOW LEVEL INPUT CABLE	USED WHEN RCA CONNECTORS ARE THE SOURCE OF INPUT TO THE AMPLIFIER, TYPICALLY USED WITH AFTERMARKET SOURCE UNITS (PREFERRED METHOD).
HIGH LEVEL INPUT CABLE	USED WHEN SPEAKER WIRES ARE THE ONLY SOURCE OF INPUT TO THE AMPLIFIER, TYPICALLY USED WITH A FACTORY SOURCE UNIT.
LOW LEVEL LINK CABLE	USED TO LINK TWO OR MORE AMPLIFIERS TO THE SAME INPUT SOURCE, TYPICALLY USED IN MULTIPLE AMPLIFIER INSTALLATIONS.
BATWING FAIRING	HARLEY-DAVIDSON® TERM FOR THE FAIRINGS ON ELECTRA GLIDE (FLHT) MODELS, FORK MOUNTED, SINGLE HEADLIGHT STYLE.
SHARKNOSE FAIRING	HARLEY-DAVIDSON® TERM FOR THE FAIRINGS ON ROAD GLIDE (FLTR) MODELS, FRAME MOUNTED (FIXED), DUAL HEADLIGHT STYLE.
MANUFACTURER INSTRUCTIONS	REFERS TO ANY DOCUMENTATION PROVIDED BY A MANUFACTURER OTHER THAN HAWG WIRED (IE. HARLEY-DAVIDSON® SHOP REPAIR MANUAL, AFTERMARKET SOURCE UNIT OR SPEAKER MANUAL, ETC.).

QUICK CONNECT SYMBOLS:

KEEP AN EYE OUT FOR THE “QUICK CONNECT” SYMBOLS THROUGHOUT THIS MANUAL; THEY PROVIDE A VISUAL LINK BETWEEN INSTRUCTIONS, DIAGRAMS, AND THE AMPLIFIER CONNECTIONS.

POWER		BATTERY POSITIVE (+12VDC)
GROUND		BATTERY NEGATIVE (-), CHASSIS GROUND
REMOTE		REMOTE TURN-ON LEAD ACTIVATED BY +12VDC
FUSE		ESSENTIAL PROTECTION FROM SHORTS
LINE-IN		SOURCE INPUT, LOW LEVEL OR HIGH LEVEL INPUT
LINE-OUT		LOW LEVEL OUTPUT, FEED FOR ADDITIONAL AMPLIFIER DEVICE LINKING
SPEAKER		TERMINAL BLOCK CONNECTIONS FOR SPEAKER OUTPUT
CONFIGURE		AMPLIFIER CONFIGURATION AND TEST (GAIN, CROSSOVERS, ETC.)
RC-LINK IN		RC-LINK INPUT PORT, REMOTE CONTROL OR AMPLIFIER LINKING
RC-LINK OUT		RC-LINK OUTPUT PORT, AMPLIFIER LINKING
TOOLS		TOOLS REQUIRED, DISASSEMBLY OR REASSEMBLY WORK TO PERFORM
CAUTION		CAUTIONS, NOTES, TIPS, OR SPECIFIC INFORMATION TO BE AWARE OF

NOTE: IF ANYTHING ABOUT THE INSTRUCTION OR INFORMATION PROVIDED IN THIS MANUAL IS UNCLEAR, QUESTIONABLE, OR YOU THINK WE'RE DEAD WRONG ABOUT SOMETHING, PLEASE CONTACT US.

INSTALLATION INSTRUCTIONS

INITIAL TEAR-DOWN



IF YOU HAVEN'T ALREADY, GET FAMILIAR WITH YOUR NEW SYSTEM BY BROWSING THE "USER GUIDE" SECTION OF THIS MANUAL. UNDERSTANDING YOUR EQUIPMENT FIRST CAN MAKE THE INSTALLATION INSTRUCTIONS EASIER TO FOLLOW.



1. WITH THE IGNITION SWITCH OFF, REMOVE THE SEAT.

WARNING: KEEP THE IGNITION SWITCH OFF THROUGHOUT THE ENTIRE INSTALLATION PROCESS.

TIP: REFER TO MANUFACTURER INSTRUCTIONS IF NECESSARY.



2. DISCONNECT THE NEGATIVE (-) SIDE OF THE BATTERY, FOLLOWED BY THE POSITIVE (+) SIDE.

WARNING: BE SURE TO PREVENT THE LOOSE BATTERY CABLES FROM CONTACTING THE EXPOSED BATTERY TERMINALS ACCIDENTALLY DURING THE INSTALLATION PROCESS.



3. CAREFULLY REMOVE THE FRONT FAIRING COVER, NOTING SPECIFICALLY WHICH HOLE EACH SCREW COMES FROM AS LENGTHS AND SIZES MAY VARY.

TIP: REFER TO MANUFACTURER INSTRUCTIONS IF NECESSARY, AND DON'T FORGET TO COVER YOUR FENDER.



WHILE YOU HAVE THIS THING APART, TAKE A MINUTE TO CHECK A FEW THINGS AT THE SAME TIME. BURNT OUT GAUGE BULBS, LOOSE HARNESS CONNECTORS CAUSING RATTLES, THAT SEAL THAT NEVER FAILS TO FALL OFF THE EDGE OF THE INNER FAIRING WITHOUT SOME TRIM ADHESIVE, INSTALLING THOSE NEW GAUGES YOU'VE BEEN WANTING TO GET...



4. DISCONNECT THE SPEAKER WIRES FROM THE FACTORY SPEAKERS IN THE FAIRING AND SET ASIDE FOR **HIGH-LEVEL INPUT** USE LATER.

TIP: CUTTING A FEW WIRE TIES AND PULLING BACK LOOM CAN MAKE YOUR HARNESS EASIER TO WORK WITH.



AT THIS POINT, TAKE A VISUAL INVENTORY OF YOUR INNER FAIRING. SECURE ANY LOOSE WIRES OR LOOMS AWAY FROM MOUNTING LOCATIONS WITH ZIP TIES. WITH THE MAIN AMPLIFIER TEMPORARILY IN PLACE, PERFORM A TEST FIT OF THE FRONT FAIRING COVER TO ENSURE THAT NO CONTACT OCCURS BEFORE PROCEEDING.

INSTALLATION INSTRUCTIONS [CONTINUED]

COMPONENT MOUNTING

✋ USING VELCRO® AS A MOUNTING METHOD HAS THE FOLLOWING ADVANTAGES; IT HOLDS WELL UNDER EXTREME VIBRATION CONDITIONS, PROVIDES A MEASURE OF SHOCK ABSORPTION, AND ALLOWS FOR SIMPLE INSTALLATION, REMOVAL, AND ADJUSTMENT. HOWEVER, ONCE YOU STICK THOSE TWO SIDES TOGETHER WITH SOME PRESSURE, YOU'D DO WELL TO USE A PUTTY KNIFE SEPARATING THE TWO AGAIN. USING A PIECE OF PAPER OR THIN CARDBOARD BETWEEN THE 2 PIECES OF VELCRO WHEN TEST FITTING CAN MAKE THINGS A LOT EASIER.

NOTE: BE SURE TO CLEAN ALL MATING SURFACES WITH THE INCLUDED ALCOHOL PADS BEFORE ATTACHING THE ADHESIVE VELCRO® PATCHES. ONCE THE ADHESIVE SIDE IS APPLIED TO A CLEAN SURFACE, WORK OUT THE AIR POCKETS WITH YOUR FINGER TIPS FOR MAXIMUM HOLDING STRENGTH AND LONGEVITY.

⊕ 5. DETERMINE THE MOUNTING LOCATION FOR THE AMPLIFIER BASED ON YOUR FAIRING:

5.1. FLHT/X (BATWING) FAIRINGS

MOUNT THE **AMPLIFIER** ON TOP OF THE SOURCE UNIT USING THE VELCRO® PATCH PROVIDED.

MULTIPLE AMPLIFIERS:

IF INSTALLING TWO AMPLIFIERS, USE OF THE **AB150** BRACKET IS RECOMMENDED. MOUNTED ON THE SIDE OF THE FAIRING BRACE, A SECOND AMPLIFIER CAN BE INSTALLED BETWEEN THE RADIO AND SPEAKER MAGNET. BE SURE TO ALLOW ENOUGH CLEARANCE AROUND THE AMPLIFIER HOUSINGS TO AVOID VIBRATION CONTACT WITH OTHER OBJECTS.

2006 AND NEWER:

IF ONLY ONE FACTORY MODULE IS INSTALLED ABOVE THE SOURCE UNIT, INSTALL THE **HKA150** ADAPTER BRACKET (SOLD SEPARATELY) IN THE BLANK MODULE SLOT TO PROVIDE A LEVEL MOUNTING SURFACE.

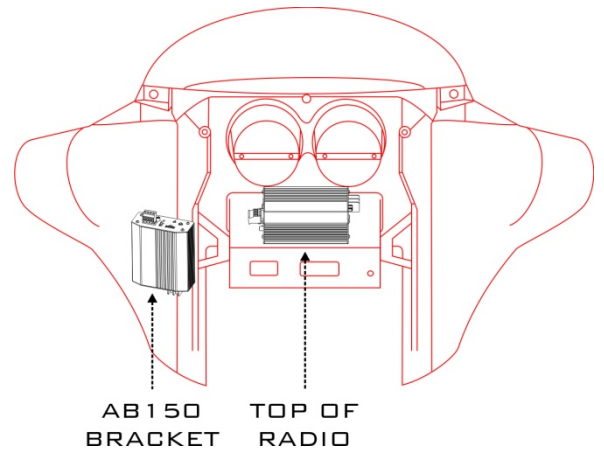

5.2. FLTR (SHARKNOSE) FAIRINGS

MOUNT THE **AMPLIFIER** ON THE FLAT INNER FAIRING SURFACE BEHIND THE GLOVE BOX USING THE VELCRO® PATCH PROVIDED.

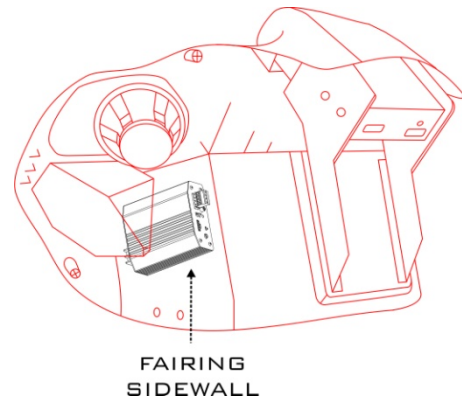

⊕ 5.3. CUSTOM INSTALLS - MOUNTING LOCATIONS WILL VARY, AND MUST BE TEST FIT ON A ONE-BY-ONE BASIS. CHECK FOR PROPER CLEARANCES FOR WIRING AND CONNECTORS BEFORE COMMITTING TO A GIVEN LOCATION. THE HAWG WIRED WIRING KIT (SOLD SEPERATELY) MAY NOT INCLUDE LONG ENOUGH WIRING NEEDED TO COMPLETE CUSTOM INSTALLATIONS.

✋ FOR ALL "TOP OF THE SOURCE UNIT" INSTALLATIONS, ENSURE THAT THE AMPLIFIER(S) IS POSITIONED AS FAR BACK TOWARDS THE INNER FAIRING AS POSSIBLE, LEAVING JUST ENOUGH ROOM FOR WIRING AND CONNECTORS.

INSTALLATION INSTRUCTIONS [CONTINUED]

WIRING THE AMPLIFIER

⚠ SOME BIKES MAY REQUIRE THAT THE FUEL TANK BE LOOSENED OR REMOVED TO PROPERLY ROUTE THE POWER WIRE. PLEASE TAKE EVERY POSSIBLE PRECAUTION NECESSARY WHEN DEALING WITH YOUR FUEL TANK!

- ⚡** 6. ROUTE AND CONNECT THE POWER WIRE (**WITHOUT THE IN-LINE FUSE INSTALLED**) FROM THE POSITIVE (+) BATTERY TERMINAL (**FIG. 6.A**), UNDER THE RIGHT (THROTTLE) SIDE OF THE FUEL TANK, THROUGH THE FAIRING, AND TO THE MAIN AMPLIFIER TERMINAL LABELED **PWR**. THE BLACK SLEEVE SHOULD END UP COVERING THE EXPOSED POWER WIRE BETWEEN THE FUEL TANK AND THE FAIRING.

WARNING: DO NOT INSTALL THE IN-LINE FUSE UNTIL INSTRUCTED TO DO SO (END OF INSTALLATION).

NOTE: ON 2006 AND NEWER, WE RECOMMEND UTILIZING THE FACTORY WIRING HARNESS CHANNEL UNDER THE TANK WITH A SUITABLE WIRE FEEDING TOOL OR DEVICE. USE OF A COAT HANGER IS AT YOUR OWN RISK.

- ⬇** 7. ROUTE AND CONNECT THE GROUND WIRE FROM CHASSIS GROUND (**FIG. 7.B**), TO THE AMPLIFIER TERMINAL LABELED **GND**. TYPICALLY AN EXISTING SCREW OR NUT ON THE BIKE FRAME SHOULD BE USED, PREFERABLY WHERE A FACTORY GROUND STRAP ALREADY EXISTS.

TIP: THE MAJORITY OF PROBLEM INSTALLS ARE THE RESULT OF A POOR GROUND.

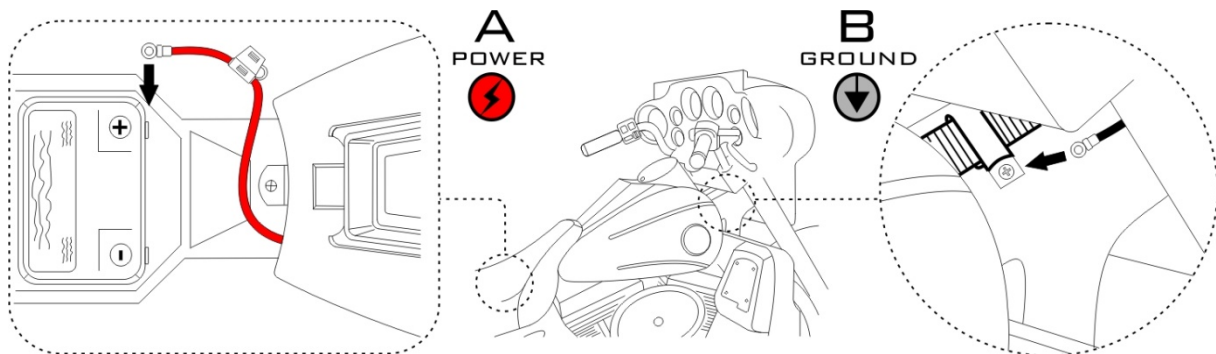

FIGURE 6 & 7 – POWER AND GROUND ROUTING AND CONNECTIONS

⚠ IF USING HIGH-LEVEL INPUT FROM A FACTORY OR AFTERMARKET RADIO, THE REMOTE TURN-ON WIRE IS NOT REQUIRED AS THE AMPLIFIERS FEATURE AUTOMATIC TURN-ON CIRCUITRY ON THE HIGH-LEVEL INPUTS. NICE, RIGHT?

- 🌀** 8. ROUTE AND CONNECT THE REMOTE TURN-ON WIRE FROM THE AMPLIFIER TERMINAL LABELED **REM** TO ONE OF THE FOLLOWING LOCATIONS:

- 8.1. **IGNITION SWITCH TURN-ON**
DISCONNECT THE POWER TERMINAL FROM THE BACK OF THE LIGHTER (**FIG. 8.A**) AND CONNECT IT TO THE MALE TERMINAL OF THE REMOTE TURN-ON WIRE (**FIG. 8.B**). CONNECT THE FEMALE TERMINAL TO THE LIGHTER TERMINAL (**FIG. 8.C**) AND THE REMOTE LEAD TO THE AMPLIFIER.

- 8.2. **AFTERMARKET SOURCE UNITS**
CONNECT THE REMOTE INPUT OF THE AMPLIFIER TO YOUR SOURCE UNIT'S AMPLIFIER REMOTE TURN-ON WIRE.

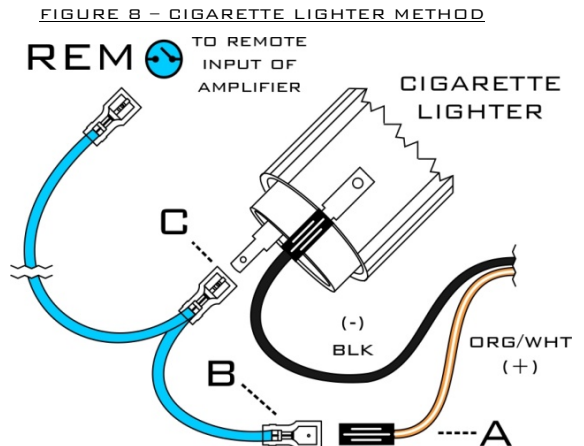

INSTALLATION INSTRUCTIONS [CONTINUED]

WIRING THE AMPLIFIER (CONTINUED)

-  9. DETERMINE AND CONNECT YOUR SOURCE UNIT OUTPUT TO THE AMPLIFIER INPUTS USING ONE OF THE FOLLOWING **HIGH OR LOW LEVEL INPUT** METHODS:

9.1. FACTORY SOURCE UNITS - HIGH LEVEL INPUT (NO RCA CONNECTORS AVAILABLE)

CONNECT THE FACTORY SPEAKER OUTPUT WIRES TO THE HIGH LEVEL INPUT CABLE (USE ATTACHED TERMINALS TO CONNECT INPUT WIRES TO THE SPEAKER WIRE TERMINALS IF POSSIBLE).

NOTE: FOR CUSTOM WIRING CONNECTIONS, WE RECOMMEND CRIMP, SOLDER, AND HEAT SHRINK.

HIGH LEVEL INPUT CABLE(S)		CONNECT TOGETHER	H-D® SOURCE UNIT MODELS		
2 CHANNEL – USE FRONT ONLY			1998-20XX FRONT	1998-2005 REAR	2006-20XX REAR
LEFT +	WHT		WHT/ORG (PIN 16)	BRN (PIN 10)	BRN (PIN 2)
LEFT -	BLK (WHT TWIST)		L.GRN/WHT (PIN 17)	WHT/BRN (PIN 3)	WHT/BRN (PIN 25)
RIGHT +	RED		GRY/RED (PIN 18)	GRN (PIN 11)	GRN (PIN 1)
RIGHT -	BLK (RED TWIST)		L.GRN/BLK (PIN 1)	L.GRN/BRN (PIN 4)	L.GRN/BRN (PIN 24)

PIN NUMBERS APPLY TO H-D RADIO HARNESS CONNECTORS

NOTE¹: CVD BIKES MAY BE EQUIPPED WITH A HIGH-OUTPUT SOURCE UNIT; **DO NOT USE THE FOLLOWING WIRE COLORS: WHT/PNK, PNK, WHT/GRY, GRY.** THESE OUTPUTS CAN DAMAGE THE AMPLIFIER INPUTS.

9.2. AFTERMARKET SOURCE UNITS - LOW LEVEL INPUT (RCA CONNECTORS AVAILABLE)

CONNECT THE **FRONT** RCA OUTPUT CONNECTORS FROM THE SOURCE UNIT TO THE LOW LEVEL INPUT CABLE AND INPUT JACK ON THE FRONT OF THE AMPLIFIER.

 **TIP:** VERY LITTLE DIELECTRIC GREASE IS REQUIRED TO KEEP YOUR CONNECTIONS CORROSION FREE. VERY LITTLE MOISTURE IS REQUIRED TO CORRODE CONTACTS NOT COVERED WITH DIELECTRIC GREASE.

-  10. PLUG THE CHOSEN INPUT CABLE INTO THE CORRESPONDING CONNECTOR OF THE MAIN AMPLIFIER LABELED **HIGH OR LOW** ACCORDINGLY.

WIRING THE SPEAKERS

-  11. REMOVE STOCK SPEAKERS FROM THE BIKE AND INSTALL NEW SPEAKERS OF YOUR CHOICE.
NOTE: IF YOU ARE INSTALLING HAWG WIRED SPEAKERS, REFER TO THE INSTALLATION INSTRUCTIONS THAT CAME WITH THEM. IF INSTALLING ANOTHER BRAND OF SPEAKERS, REFER TO THOSE MANUFACTURER SPECIFIC INSTRUCTIONS IF NECESSARY.

-  12. ROUTE AND CONNECT THE SPEAKER WIRES FROM EACH SPEAKER OF YOUR SYSTEM TO THE CORRESPONDING SPEAKER TERMINAL PLUG (RIGHT/LEFT) AND CONNECT TO THE AMPLIFIER.

NOTE: KEEP THE POLARITIES (+/-) OF EACH WIRE PAIR CORRECT BETWEEN THE AMPLIFIER(S) AND SPEAKERS. IF YOU ARE INSTALLING HAWG WIRED SPEAKERS, REFER TO THE INSTALLATION INSTRUCTIONS THAT CAME WITH THEM. IF INSTALLING ANOTHER BRAND OF SPEAKERS, REFER TO THOSE SPECIFIC MANUFACTURER INSTRUCTIONS IF NECESSARY.

INSTALLATION INSTRUCTIONS [CONTINUED]

TESTING AND TUNING THE SYSTEM

-  13. RE-CONNECT THE POSITIVE (+) SIDE OF THE BATTERY, FOLLOWED BY THE NEGATIVE (-) SIDE.

WARNING: DO NOT INSTALL THE IN-LINE FUSE UNTIL AFTER THIS STEP.

 THIS IS A GOOD TIME TO RE-CHECK YOUR CONNECTIONS **BEFORE INSTALLING THE FUSE**. MAKE SURE THAT CONNECTORS ARE COMPLETELY SEATED AND LATCHED INTO THEIR RESPECTIVE CONNECTORS, AND THAT POWER AND GROUND IS PROPERLY CONNECTED TO THE AMPLIFIER TERMINALS.

-  14. INSTALL THE 30 AMP ATC FUSE INTO THE IN-LINE FUSE HOLDER ON THE POWER WIRE.

NOTE: IF THE FUSE DOESN'T BLOW WHEN YOU PLUG IT IN, YOU'VE PASSED THE INITIAL SMOKE TEST.

-  15. PERFORM A BASIC SYSTEM TEST. TURN THE KEY TO THE ACCESSORY POSITION AND VERIFY THAT THE AMPLIFIER POWERS UP (LED ON THE FACEPLATE SHOULD LIGHT) AND THAT THE SPEAKERS FUNCTION PROPERLY. IF NOT, PROCEED DIRECTLY TO “**TROUBLESHOOTING**” IN THE **USER GUIDE** SECTION.

-  16. CONFIGURE, TEST, AND TUNE YOUR SYSTEM BY FOLLOWING THE “**TEST AND TUNE**” INSTRUCTIONS GIVEN IN THE “**USER GUIDE**” SECTION OF THIS MANUAL. WHEN YOU'VE COMPLETED THESE INSTRUCTIONS AND ARE READY TO ROCK AND ROLL, RETURN HERE TO COMPLETE THE INSTALLATION.

 NOW IT'S TIME TO START ROTATING KNOBS AND FLIPPING SWITCHES TO GET THE MOST OUT OF YOUR NEW SYSTEM. IF YOU ARE USING A HAWG WIRED REMOTE CONTROL DEVICE (SOLD SEPERATELY), PLEASE REFER TO THE INSTALLATION GUIDE PROVIDED WITH THAT PRODUCT. IF YOU RUN INTO ANY SNAGS ALONG THE WAY, LET US KNOW SO WE CAN HELP GET YOU UP AND RUNNING.

WRAPPING IT UP

-  17. WITH THE IGNITION OFF, CAREFULLY INSTALL THE FAIRING COVER, ENSURING THAT EACH ATTACHING SCREW GOES BACK INTO THE HOLE IT CAME OUT OF. ONCE YOU HAVE EVERYTHING LINED UP AND ALL SCREWS LOOSELY INSTALLED, TIGHTEN EACH SCREW IN AN EVEN PATTERN TO AVOID BINDING.

WARNING: AVOID OVER-TIGHTENING; PLASTIC THREADS AND BRASS INSERTS HAVE A TENDENCY TO STRIP OR PULL OUT EASILY. REFER TO MANUFACTURER INSTRUCTIONS IF NECESSARY.

-  18. INSTALL THE SEAT, TAKING CARE NOT TO DAMAGE OR PINCH YOUR FACTORY WIRING HARNESS OR NEW AMPLIFIER POWER WIRE.

TIP: BE SURE THAT BOTH BATTERY TERMINALS ARE CONNECTED AND TIGHT, AND THAT ANY FUEL TANK BOLTS LOOSENED EARLIER ARE NOW TIGHT. REFER TO MANUFACTURER INSTRUCTIONS IF NECESSARY.

-  19. PERFORM A FINAL SYSTEM TEST. TURN THE KEY TO THE ACCESSORY POSITION AND VERIFY THAT ALL COMPONENTS STILL FUNCTION PROPERLY.

-  20. PERFORM A TEST RIDE AND AGAIN VERIFY THAT THE SYSTEM IS OK, AND THAT YOUR FRIENDS ARE SUFFICIENTLY JEALOUS.

TIP: JUSTIN WOULD LIKE TO REMIND YOU TO CHECK YOUR TIRE PRESSURE, AND FROM THE ENTIRE HAWG WIRED TEAM, THANKS FOR MAKING THIS POSSIBLE, KEEP THE RUBBER SIDE DOWN, AND CRANK IT!

USER GUIDE

CONNECTORS AND CONTROLS

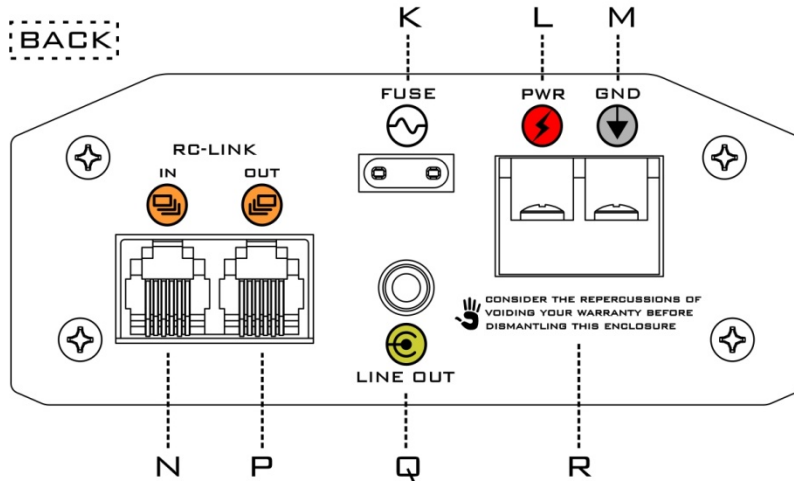
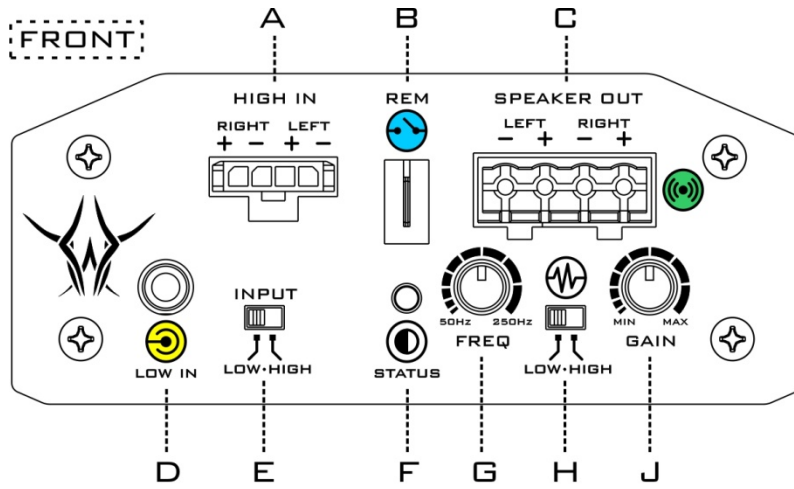

PLANNING YOUR SYSTEM CONFIGURATION IS THE FIRST STEP TOWARDS HI-FI HAPPINESS, SO IT'S TIME YOU GET FAMILIAR WITH ALL THE BELLS AND WHISTLES YOUR NEW SYSTEM HAS TO OFFER. THE TABLE BELOW LISTS THE CONTROLS AND CONNECTORS OF THE AMPLIFIER MODULE FOR REFERENCE.

A	HIGH LEVEL INPUT	G	CROSSOVER ADJUST KNOB	N	RC-LINK INPUT JACK
B	REMOTE TURN-ON CONNECTOR	H	HIGH/LOW CROSSOVER SWITCH	P	RC-LINK OUTPUT JACK
C	SPEAKER OUTPUT TERMINALS	J	INPUT GAIN ADJUST KNOB	Q	LINE LEVEL OUTPUT
D	LOW LEVEL INPUT	K	AMPLIFIER PROTECTION FUSE	R	GOOD ADVICE
E	HIGH/LOW LEVEL INPUT SWITCH	L	MAIN POWER TERMINAL		
F	AMPLIFIER STATUS LED	M	MAIN GROUND TERMINAL		

USER GUIDE [CONTINUED]

CONNECTORS DEFINED



HIGH LEVEL INPUT CONNECTOR:

THIS CONNECTOR ALLOWS THE AMPLIFIER TO USE SPEAKER OUTPUTS FROM A SOURCE UNIT AS INPUTS TO THE AMPLIFIER. THIS IS THE ONLY WAY TO CONNECT A FACTORY HARLEY-DAVIDSON® SOURCE UNIT TO THIS SYSTEM. THIS METHOD OF INPUT ALSO PROVIDES AUTOMATIC TURN-ON FOR THE AMPLIFIER, RENDERING THE REMOTE TURN-ON WIRE UNNECESSARY.

WIRE COLORS FOR THE HIGH LEVEL INPUT CABLE(S):

	LEFT (+)	LEFT (-)	RIGHT (+)	RIGHT (-)
HIGH LEVEL CABLE	WHITE	BLACK/ TWISTED WITH WHITE	RED	BLACK/ TWISTED WITH RED



LOW LEVEL INPUT CONNECTOR:

THIS CONNECTOR ALLOWS THE AMPLIFIER TO USE INDUSTRY STANDARD RCA OUTPUTS FROM AN AFTERMARKET SOURCE UNIT AS INPUTS TO THE AMPLIFIER. THIS IS THE PREFERRED METHOD WHEN RCA OUTPUTS ARE AVAILABLE, AND WILL PRODUCE THE CLEANEST SOURCE SIGNAL TO THE AMPLIFIER.

NOTE: WE USE INDUSTRY STANDARD 3.5MM HEADPHONE STYLE JACKS ON THE AMPLIFIER DUE TO THE SPACE CONSTRAINTS (A 3.5MM PHONO JACK IS A LOT SMALLER THAN 2 RCA JACKS). ALTHOUGH WE HIGHLY RECOMMEND USING THE LOW LEVEL INPUT CABLE PROVIDED WITH THE KIT, TECHNICALLY YOU SHOULD BE ABLE TO UTILIZE ANY STANDARD RCA TO PHONO ADAPTER CABLE FOUND AT YOUR LOCAL ELECTRONIC STORE TO MAKE THESE CONNECTIONS.



LOW LEVEL OUTPUT CONNECTOR:

THIS CONNECTOR PROVIDES A LOW LEVEL OUTPUT SIGNAL TO PASS ALONG A CLEAN AUDIO FEED TO ADDITIONAL AMPLIFIERS. THIS IS THE PREFERRED METHOD FOR CONNECTING MULTIPLE AMPLIFIERS TO ONE SOURCE UNIT RATHER THAN USING Y ADAPTERS ON THE INPUT SIDE.

NOTE: WE USE INDUSTRY STANDARD 3.5MM HEADPHONE STYLE JACKS ON THE AMPLIFIER DUE TO THE SPACE CONSTRAINTS (A 3.5MM PHONO JACK IS A LOT SMALLER THAN 2 RCA JACKS). ALTHOUGH WE HIGHLY RECOMMEND USING THE LOW LEVEL LINK CABLES WE SUPPLY WITH OUR REMOTE CONTROL AND LINKING KITS, TECHNICALLY YOU SHOULD BE ABLE TO UTILIZE ANY STANDARD PHONO JACK ADAPTER CABLE FOUND AT YOUR LOCAL ELECTRONIC STORE TO MAKE THESE CONNECTIONS.



SPEAKER OUTPUT TERMINAL PLUG:

THIS CONNECTOR PROVIDES THE CONNECTIONS TO THE SPEAKERS. DO NOT USE WIRE THAT EXCEEDS 12AWG, AND TAKE CARE TO NOT OVER-TIGHTEN THE TERMINAL SCREWS.



RC-LINK IN/OUT JACKS:



THESE CONNECTORS PROVIDE THE INTERFACE AND LINKING FOR HAWG WIRED'S PROPRIETARY REMOTE CONTROL DEVICES (SOLD SEPERATELY). NO OTHER DEVICE OR CABLE SHOULD EVER BE CONNECTED TO THESE PORTS. PLEASE REFER TO THE DOCUMENTATION PROVIDED WITH THE REMOTE CONTROL FOR PROPER CONNECTION AND USAGE.

NOTE: IF YOU DON'T HAVE A HAWG WIRED REMOTE CONTROL DEVICE, NOW WOULD BE A GOOD TIME TO GET ONE...

USER GUIDE [CONTINUED]

CONTROLS DEFINED



INPUT GAIN ADJUSTMENT:

A COMMON MISCONCEPTION ABOUT GAIN ADJUSTMENT ON AMPLIFIERS IS THAT “MORE GAIN = MORE VOLUME”. ACTUALLY, IT’S NOT THE VOLUME THAT’S BEING INCREASED, BUT RATHER THE AMPLIFIER’S SENSITIVITY TO THE SOURCE INPUT. BY INCREASING THE GAIN LEVEL, YOU’RE INCREASING HOW SENSITIVE THE AMPLIFIER IS TO THE SIGNAL IT RECEIVES FROM THE SOURCE UNIT. THIS IS WHY IT’S IMPORTANT TO SET THE GAIN PROPERLY, RATHER THAN SIMPLY TURNING THE KNOB UNTIL IT’S REALLY LOUD.



GAIN ALLOWS THE FOLLOWING NOMINAL OPERATING LEVEL ADJUSTMENTS:

- LOW LEVEL INPUT (RCA LINE-IN) - 250MV TO 2.5V**
- HIGH LEVEL INPUT (SPEAKER-IN) - 500MV TO 5V**

THESE VOLTAGE LEVELS CAN ACCOMMODATE VIRTUALLY ANY HARLEY-DAVIDSON® OR OTHER BRAND OF CAR, MARINE, OR MOTORCYCLE SOURCE UNITS, AS WELL AS JUST ABOUT ANYTHING THAT HAS RCA OR LINE-OUT STYLE OUTPUTS.



WARNING: SETTING THE GAIN TOO HIGH IN AN ATTEMPT TO GET “MORE VOLUME” CAN NOT ONLY CAUSE PREMATURE DISTORTION, BUT CAN ALSO DAMAGE YOUR SPEAKERS. **IF YOUR SYSTEM CONFIGURATION RESULTS IN YOUR GAIN CONTROL BEING SET OUTSIDE THE TYPICAL RANGE AS INDICATED ABOVE, CALL US TO RESOLVE THE PROBLEM.**



CROSSOVER MODE SWITCH:

THIS SWITCH SELECTS WHICH RANGE OF FREQUENCIES THAT THE BUILT-IN CROSSOVER WILL FILTER. EACH MODE IS EQUIPPED WITH 12DB PER OCTAVE ELECTRONIC FILTERS FOR PRECISE FREQUENCY ATTENUATION WITH MINIMAL PHASE DISTORTION. THE OPTIONS ARE AS FOLLOWS:

XOVER



LOW·HIGH

LOW - LOW PASS - USED WHEN SPEAKER OUTPUTS WILL DRIVE SUBWOOFERS OR LOW RANGE SPEAKERS ONLY.

XOVER



LOW·HIGH

HIGH - HIGH PASS (DEFAULT) - USED WHEN SPEAKER OUTPUTS WILL DRIVE MIDDLE TO HIGH RANGE SPEAKERS ONLY.

RECOMMENDED SETTING FOR ALL MID-RANGE AND TWEETER SPEAKERS.

USER GUIDE [CONTINUED]

CONTROLS DEFINED (CONTINUED)



CROSSOVER FILTER ADJUSTMENT:

THE PURPOSE OF A CROSSOVER CIRCUIT IS TO FILTER OUT A SPECIFIC RANGE OF FREQUENCIES FROM A SPEAKER'S INPUT TO MAXIMIZE ITS PERFORMANCE. FOR A TWEETER, THE GOAL IS TO FILTER OUT LOW (BASS) RANGE FREQUENCIES TO MAXIMIZE THE HIGH RANGE (TREBLE) RESPONSE. CONVERSELY, FOR A SUBWOOFER, THE GOAL IS TO FILTER OUT THE HIGH AND MID RANGE FREQUENCIES, LEAVING ONLY LOW FREQUENCIES TO PLAY THROUGH THE WOOFER.

THERE ARE TWO KINDS OF CROSSOVER IMPLEMENTATIONS, **ACTIVE** OR **PASSIVE**:

ACTIVE CROSSOVER - THIS FILTERS SELECTED FREQUENCIES **BEFORE** THE AUDIO SIGNAL IS AMPLIFIED BETWEEN THE SOURCE UNIT AND AMPLIFIER. OUR BUILT-IN CROSSOVERS ARE AN EXAMPLE OF THIS TYPE OF CROSSOVER.

THE GOOD - BY REMOVING UNWANTED FREQUENCIES FROM THE SIGNAL **BEFORE** IT'S AMPLIFIED, YOUR OUTPUT BECOMES MORE EFFICIENT, ONLY WORKING TO AMPLIFY THE DESIRED RANGE OF FREQUENCIES.

THE BAD - BY REMOVING UNWANTED FREQUENCIES FROM THE SIGNAL **BEFORE** IT'S AMPLIFIED, YOU ARE DEDICATING THOSE FILTERED CHANNELS TO ONLY PROVIDE A CERTAIN FREQUENCY RANGE.

PASSIVE CROSSOVER - THIS FILTERS SELECTED FREQUENCIES **AFTER** THE AUDIO SIGNAL HAS BEEN AMPLIFIED BETWEEN THE AMPLIFIER AND SPEAKER. SOME SPEAKERS ARE SOLD WITH PASSIVE CROSSOVERS INCLUDED, TYPICALLY A SMALL PLASTIC ENCLOSURE (LIKE OUR COMPONENT SERIES), OR CAPACITORS AND/OR COILS MOUNTED DIRECTLY TO THE SPEAKER (LIKE OUR UPGRADE AND PERFORMANCE SERIES).

THE GOOD - BY REMOVING UNWANTED FREQUENCIES FROM THE SIGNAL **AFTER** IT'S AMPLIFIED, YOUR AMPLIFIER'S OUTPUT IS STILL FULL RANGE, ALLOWING MORE FLEXIBLE USE, ABLE TO DRIVE TWEETERS, MID-RANGE, AND SUBWOOFERS ALIKE.

THE BAD - BY REMOVING UNWANTED FREQUENCIES FROM THE SIGNAL **AFTER** IT'S AMPLIFIED, YOU ARE FORCING THE FULL RANGE OF FREQUENCIES TO BE AMPLIFIED, REDUCING THE AMPLIFIER'S MAXIMUM POSSIBLE EFFICIENCY.



OUR BUILT-IN ACTIVE CROSSOVER(S) ARE FULLY ADJUSTABLE FROM 50HZ TO 250HZ, USING EITHER A **LOW-PASS MODE** (BASS ONLY) OR **HIGH-PASS MODE** (MIDRANGE AND HIGHS ONLY) TO EASILY MAXIMIZE YOUR SPEAKER'S POTENTIAL.

DEFAULT: WHEN USING ANY HAWG WIRED MID-RANGE OR TWEETER SPEAKERS, THE RECOMMEND SETTINGS ARE HIGH PASS MODE WITH THE FREQUENCY FILTER SET AT OR ABOVE 150HZ.

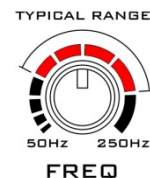

USER GUIDE [CONTINUED]

TEST AND TUNE

NOTE: IF YOU ARE USING A HAWG WIRED REMOTE CONTROL DEVICE (SOLD SEPERATELY), PLEASE REFER TO THE INSTALLATION GUIDE PROVIDED WITH THAT PRODUCT. IF YOU RUN INTO ANY SNAGS ALONG THE WAY, LET US KNOW SO WE CAN HELP GET YOU UP AND RUNNING.

SETTING THE GAIN:

WITH THE SYSTEM FUNCTIONING PROPERLY, FOLLOW THESE STEPS TO SET THE GAIN CONTROL:

1. TURN THE GAIN CONTROL(S) ALL THE WAY DOWN (COUNTER-CLOCKWISE).
2. TURN THE KEY TO THE ACCESSORY POSITION, AND THEN TURN THE SOURCE UNIT ON.
3. SET ALL **TONE** (BASS, TREBLE) AND **EQUALIZATION** CONTROLS (BALANCE, FADE) ON THE SOURCE UNIT TO "FLAT" OR "0", AND TURN OFF "LOUD" OR "LOUDNESS". IF A SEPARATE EQUALIZER IS USED, DISABLE OR SET ALL OF ITS CONTROLS TO "FLAT" OR "0".
4. WHILE PLAYING A STANDARD NON-MP3 CD¹, SET THE SOURCE UNIT'S VOLUME CONTROL TO 75% OF MAXIMUM LEVEL.
5. SLOWLY INCREASE TO GAIN CONTROL UNTIL YOU HEAR A SLIGHT DISTORTION OF THE AUDIO PLAYBACK. THIS USUALLY RESULTS IN THE KNOB BEING SET IN THE TYPICAL RANGE.



WARNING: SETTING THE GAIN TOO HIGH IN AN ATTEMPT TO GET "MORE VOLUME" CAN NOT ONLY CAUSE PREMATURE DISTORTION, BUT CAN ALSO DAMAGE YOUR SPEAKERS. IF YOUR SYSTEM CONFIGURATION RESULTS IN YOUR GAIN CONTROL BEING SET OUTSIDE THE TYPICAL RANGE AS INDICATED ABOVE, CALL US TO RESOLVE THE PROBLEM.

SETTING THE CROSSOVER:

WITH THE SYSTEM FUNCTIONING PROPERLY, FOLLOW THESE STEPS TO SET THE CROSSOVERS:

1. SELECT THE DESIRED MODE FOR EACH CROSSOVER MODE SWITCH; **LOW** FOR **LOW-PASS MODE** OR **HIGH** FOR **HIGH-PASS MODE (DEFAULT)**.
2. SET ALL TONE (BASS, TREBLE) AND EQUALIZATION CONTROLS (BALANCE, FADE) ON THE SOURCE UNIT TO "FLAT" OR "0", AND TURN OFF "LOUD" OR "LOUDNESS". IF A SEPARATE EQUALIZER IS USED, DISABLE OR SET ALL OF ITS CONTROLS TO "FLAT" OR "0" AS WELL.
3. WHILE PLAYING A STANDARD NON-MP3 CD¹, SET THE CROSSOVER FILTER TO THE DESIRED FREQUENCY (**150HZ OR ABOVE**). THIS USUALLY RESULTS IN THE KNOB BEING SET I NTHE TYPICAL RANGE.

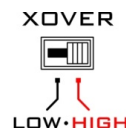

NOTE¹: THIS IS THE PREFERRED AUDIO TESTING SOURCE METHOD, AS MP3, XM, FM, AND AM ALL HAVE SOME LEVEL OF COMPRESSION OR DEGRADATION INVOLVED, WHICH CAN LEAD TO VARYING RESULTS. IF THE PREFERRED METHOD IS NOT AVAILABLE, USE THE MOST COMMON PLAYBACK METHOD YOU USE WHILE RIDING.

USER GUIDE [CONTINUED]

TROUBLESHOOTING

INFRACTION	PROBABLE CAUSE	RESTITUTION
AMPLIFIER DOESN'T POWER UP (LED IS OFF)	REM WIRE IS NOT GETTING +12V TO THE AMPLIFIER	CHECK YOUR WIRING OF THE REMOTE TURN-ON WIRE. MAKE SURE THE TURN-ON SOURCE IS PROVIDING +12V.
	PWR WIRE IS NOT GETTING +12V TO THE AMPLIFIER	CHECK THIS WIRE ALL THE WAY TO THE BATTERY. MAKE SURE THE IN-LINE FUSE IS INSTALLED AND NOT BLOWN.
	GND WIRE IS NOT GETTING GROUND TO THE AMPLIFIER	MAKE SURE THE GROUND LOCATION SELECTED IS PROVIDING A GOOD, CLEAN CHASSIS GROUND.
AMPLIFIER POWERS UP, BUT MAKES NO SOUND (LED IS ON)	SPEAKER WIRES ARE NOT CONNECTED OR SHORTED	CHECK YOUR WIRING FROM THE AMPLIFIERS TO EACH SPEAKER IN THE SYSTEM. MAKE SURE THAT THE WIRE TERMINALS ARE NOT SHORTING TO THE BIKE CHASSIS OR OTHER WIRES.
	INPUT FROM SOURCE UNIT NOT CONNECTED PROPERLY	CHECK YOUR HIGH OR LOW LEVEL INPUT WIRING FROM THE SOURCE UNIT TO THE AMPLIFIER.
	SOURCE UNIT HAS NO OUTPUT	CHECK THAT YOUR SOURCE UNIT IS FUNCTIONING PROPERLY. REFER TO MANUFACTURER INSTRUCTIONS IF NECESSARY.
SPEAKER OUTPUT SOUNDS LOW OR DISTORTED	INPUT GAIN LEVEL SET INCORRECTLY	SET THE GAIN LEVEL USING THE INSTRUCTIONS IN " TEST AND TUNE ". IF YOU'VE ALREADY COMPLETED THIS STEP, TRY LOWERING THE GAIN SLIGHTLY UNTIL THE DISTORTION STOPS.
	LOW BATTERY CONDITION	CHECK YOUR BATTERY FOR PROPER CHARGE AND REPLACE IF NECESSARY.

SYSTEM DIAGRAMS

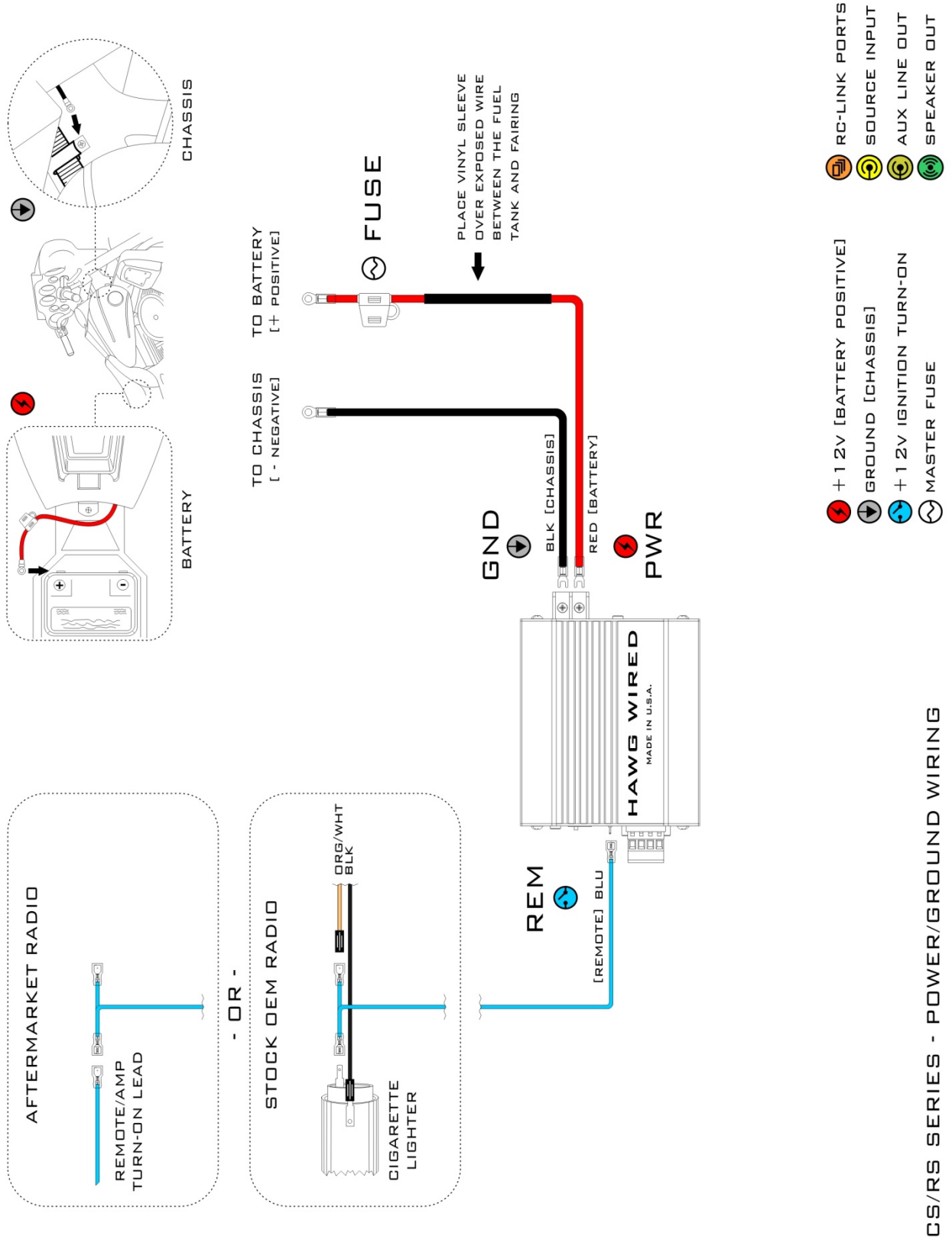

CS/RS SERIES - POWER/GROUND WIRING

SYSTEM DIAGRAMS [CONTINUED]

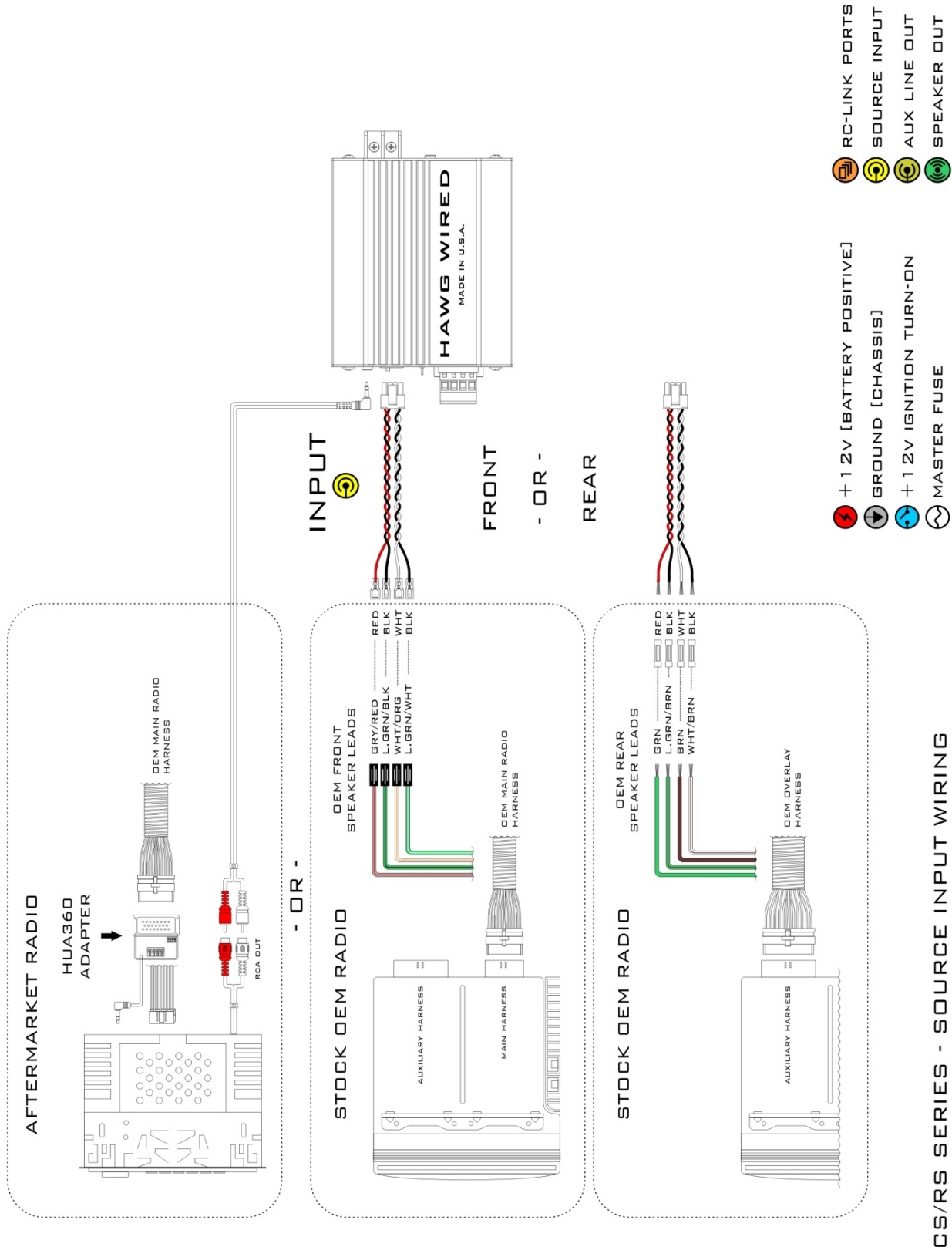

SYSTEM DIAGRAMS [CONTINUED]

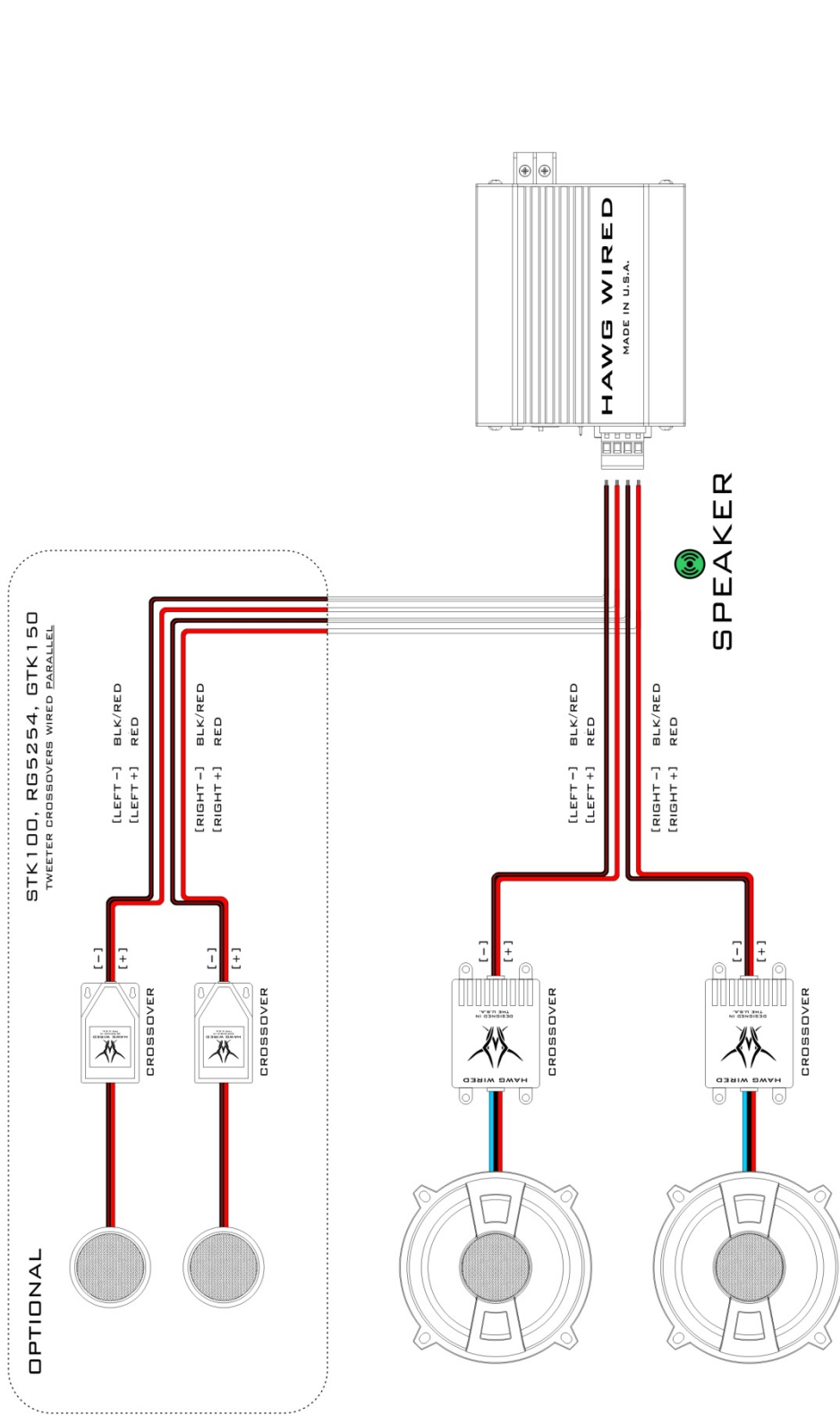

- + 1 2V [BATTERY POSITIVE]
- GROUND [CHASSIS]
- + 1 2V IGNITION TURN-ON
- MASTER FUSE
- RC-LINK PORTS
- SOURCE INPUT
- AUX LINE OUT
- SPEAKER OUT

CS/RS SERIES - 2 SPEAKER OUTPUT WIRING

SYSTEM DIAGRAMS [CONTINUED]

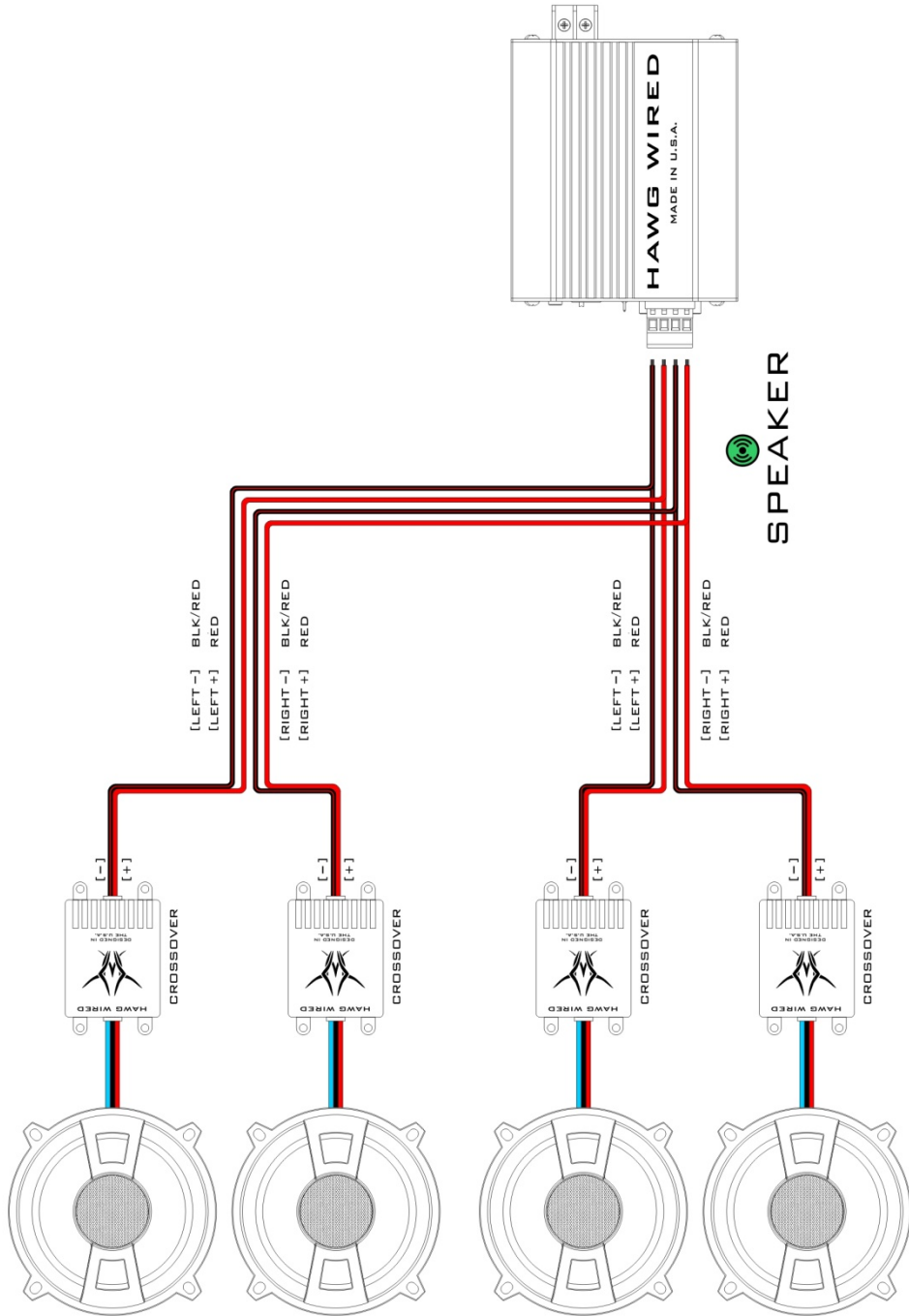

- + 1 2V [BATTERY POSITIVE]
- GROUND [CHASSIS]
- + 1 2V IGNITION TURN-ON
- MASTER FUSE
- RC-LINK PORTS
- SOURCE INPUT
- AUX LINE OUT
- SPEAKER OUT

CS/RS SERIES - 4 SPEAKER PARALLEL WIRING

SYSTEM DIAGRAMS [CONTINUED]

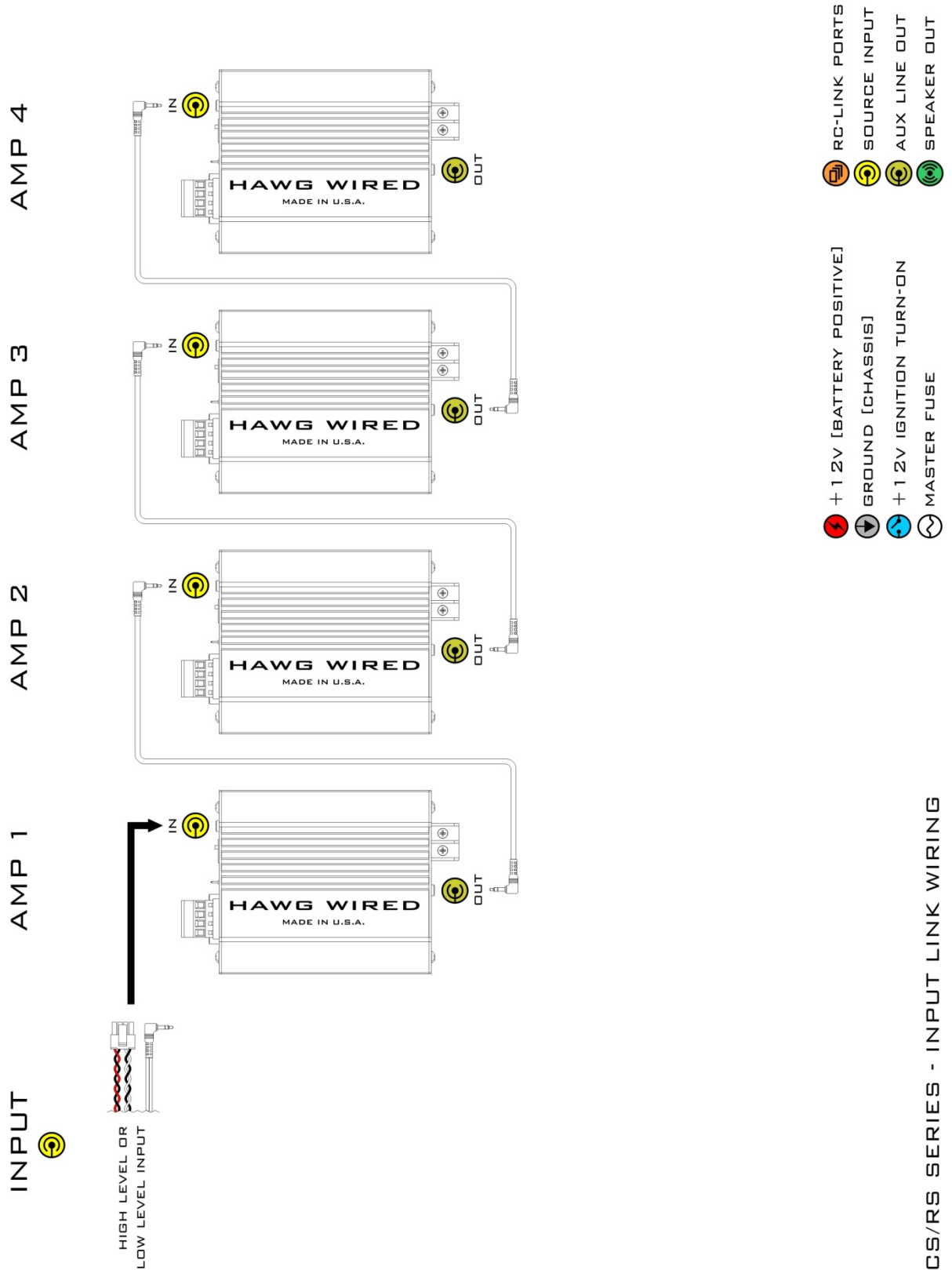

CS/RS SERIES - INPUT LINK WIRING

SYSTEM DIAGRAMS [CONTINUED]

MISCELLANEOUS / CUSTOM WIRING SOLUTIONS

POWERING TWO SPEAKERS WITH A SINGLE AMPLIFIER CHANNEL

TO DRIVE TWO SPEAKERS WITH A SINGLE AMPLIFIER CHANNEL, THE TOTAL IMPEDANCE (OR LOAD) ON THE AMPLIFIER CHANNEL MUST BE CONSIDERED. SINCE CS/RS SERIES AMPLIFIERS ARE 2 OHM STABLE, A 2 OHM OR GREATER LOAD MUST BE MAINTAINED AT THE AMPLIFIER OUTPUT.

BELOW ARE EXAMPLES OF BOTH PARALLEL AND SERIES WIRING APPLICATIONS FOR PROPER IMPEDANCE MATCHING. NOTE THAT WHILE **PARALLEL WIRING DIVIDES** THE SPEAKERS IMPEDANCE, **SERIES WIRING COMBINES** THE SPEAKER IMPEDANCES TOGETHER.

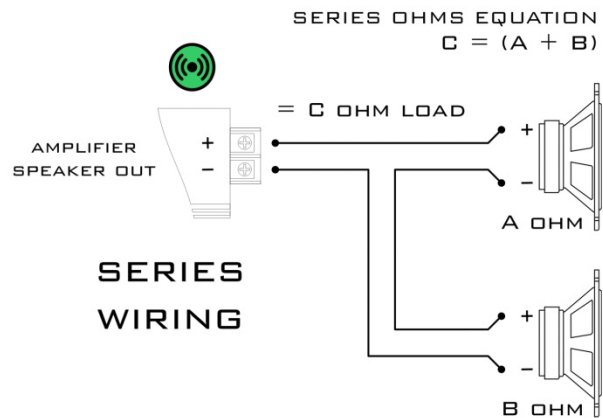
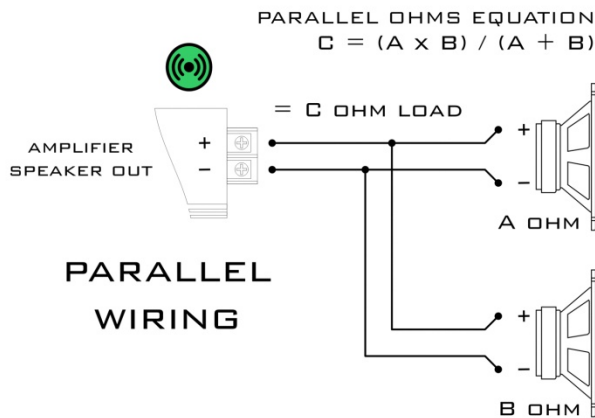

UTILIZING A MULTI-INPUT SWITCH WITH A STOCK SOURCE UNIT

IN ORDER TO UTILIZE AN AFTERMARKET LOW-LEVEL INPUT SWITCH WITH A FACTORY SOURCE UNIT, IT'S NECESSARY TO CONVERT THE STOCK HIGH-LEVEL OUTPUTS TO LOW-LEVEL BEFORE THE INPUT SWITCH ITSELF. THE DIAGRAM BELOW SHOWS AN EXAMPLE OF THIS KIND OF SWITCHED INPUT.

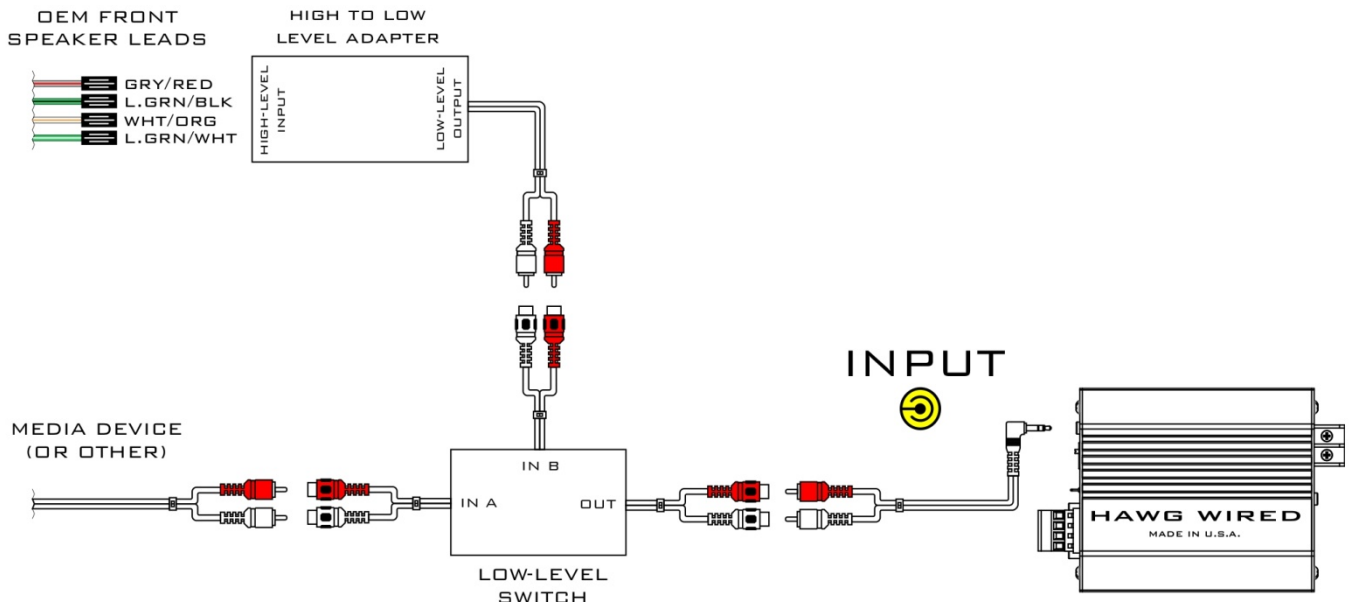

SPECIFICATIONS

CS300/RS400

SPECIFICATIONS SUBJECT TO CHANGE WITHOUT NOTICE

INPUT CHANNELS: 2 HIGH LEVEL / 2 LOW LEVEL
 OUTPUT CHANNELS: 2 CHANNELS
 FREQUENCY RESPONSE: 10HZ-50KHZ
 LOW LEVEL (RCA LINE-IN) SENSITIVITY: 200MV - 6V
 HIGH LEVEL (SPEAKER-IN) SENSITIVITY: 400MV - 12V
 INPUT IMPEDANCE: 33K OHMS
 NOMINAL OUTPUT IMPEDANCE: 4Ω (2Ω)
 CS300 - NOMINAL POWER OUTPUT (WATTS RMS @ 0.01% THD): 75 WATTS X2 (150 WATTS X2)
 RS400 - NOMINAL POWER OUTPUT (WATTS RMS): 100 WATTS X2 (200 WATTS X2)
 ENCLOSURE DIMENSIONS: 4.00" W X 4.50" L X 1.70" H

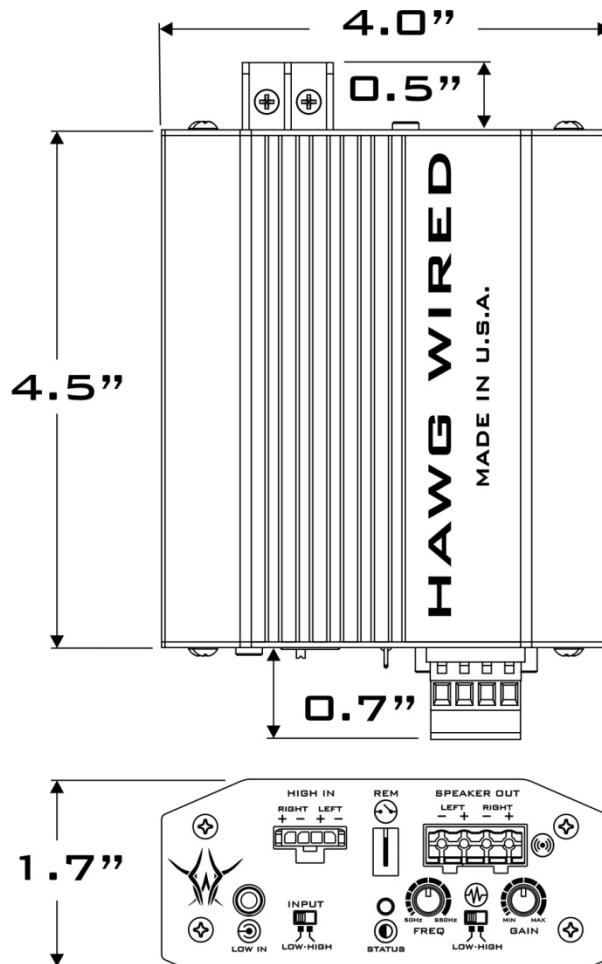

CS300/RS400

DIMENSIONS IN INCHES

WARRANTY INFORMATION

HAWG WIRED OFFERS A LIMITED WARRANTY OF OUR PRODUCTS ON THE FOLLOWING TERMS:

• **LENGTH OF WARRANTY**

1 YEAR ON AUDIO SYSTEMS, ELECTRONICS, SPEAKERS, AND ACCESSORIES (RECEIPT REQUIRED).

• **COVERAGE**

THIS WARRANTY COVERS ONLY THE ORIGINAL PURCHASER OF A HAWG WIRED PRODUCT PURCHASED FROM AN AUTHORIZED HAWG WIRED DEALER IN THE UNITED STATES. IN ORDER TO RECEIVE SERVICE, THE PURCHASER MUST PROVIDE HAWG WIRED WITH A COPY OF THE RECEIPT STATING THE CUSTOMER NAME, DEALER NAME, PRODUCT PURCHASED AND DATE OF PURCHASE.

• **DEFECTIVE PRODUCTS**

PRODUCTS FOUND TO BE DEFECTIVE DURING THE WARRANTY PERIOD WILL BE REPAIRED OR REPLACED (WITH A PRODUCT DEEMED TO BE EQUIVALENT) AT HAWG WIRED'S DISCRETION.

• **WHAT IS NOT COVERED**

DAMAGE CAUSED BY ACCIDENT, ABUSE, IMPROPER OPERATIONS, WATER, THEFT
ANY COST OR EXPENSE RELATED TO THE REMOVAL OR REINSTALLATION OF PRODUCT
SERVICE PERFORMED BY ANYONE OTHER THAN AN AUTHORIZED HAWG WIRED SERVICE CENTER
ANY PRODUCT WITH THE SERIAL NUMBER OR TAMPER LABELS DEFACED, ALTERED, OR REMOVED
SUBSEQUENT DAMAGE TO OTHER COMPONENTS
ANY PRODUCT PURCHASED OUTSIDE THE U.S.
ANY PRODUCT NOT PURCHASED FROM AN AUTHORIZED HAWG WIRED DEALER

• **LIMIT ON IMPLIED WARRANTIES**

ANY IMPLIED WARRANTIES INCLUDING WARRANTIES OF FITNESS FOR USE AND MERCHANTABILITY ARE LIMITED IN DURATION TO THE PERIOD OF THE EXPRESS WARRANTY SET FORTH ABOVE. SOME STATES DO NOT ALLOW LIMITATIONS ON THE LENGTH OF AN IMPLIED WARRANTY, SO THIS LIMITATION MAY NOT APPLY. NO PERSON IS AUTHORIZED TO ASSUME FOR HAWG WIRED ANY OTHER LIABILITY IN CONNECTION WITH THE SALE OF THE PRODUCT.

• **HOW TO OBTAIN SERVICE**

PLEASE CALL 510.894.2999 FOR HAWG WIRED CUSTOMER SERVICE. YOU MUST OBTAIN A RETURN MATERIAL AUTHORIZATION NUMBER (RMA) TO RETURN ANY PRODUCT TO HAWG WIRED. YOU ARE RESPONSIBLE FOR SHIPPING CHARGES OF RETURNED PRODUCTS TO HAWG WIRED.

• **MADE IN THE USA**

OUR PRODUCTS ARE PROUDLY DESIGNED, DEVELOPED AND BUILT IN THE USA*. THE MAJORITY OF THE COMPONENTS USED IN THE CONSTRUCTION OF OUR PRODUCTS ARE PRODUCED BY AMERICAN COMPANIES. HOWEVER, DUE TO THE GLOBAL NATURE OF MODERN MANUFACTURING AND THE ELECTRONICS INDUSTRY IN GENERAL, SOME PARTS MAY BE MANUFACTURED IN OTHER COUNTRIES.

*OUR SPEAKERS ARE PROUDLY DESIGNED AND DEVELOPED IN THE USA. HOWEVER, DUE TO THE GLOBAL NATURE OF LOUDSPEAKER MANUFACTURING, OUR SPEAKERS ARE MANUFACTURED IN OTHER COUNTRIES.

HAWG WIRED, INC.

CONTACT US BY EMAIL

SALES AND MARKETING – sales@hawg-wired.com
TECHNICAL SUPPORT – support@hawg-wired.com

CONTACT US BY PHONE

MAIN 510.894.2999
EFAX 510.217.6994

VISIT US ON THE WEB AT HAWG-WIRED.COM



COPYRIGHT © 2013 HAWG WIRED, INC. ALL RIGHTS RESERVED.

REV.1C PRINTED IN THE U.S.A.